

# EASTERN ARCHITECTURAL SYSTEMS

## HVHZ CLIPPED ALUMINUM BAY/BOW MULLIONS

### GENERAL NOTES:

1. THE PRODUCT SHOWN HEREIN IS DESIGNED AND MANUFACTURED TO COMPLY WITH THE 6TH EDITION (2017) FLORIDA BUILDING CODE, INCLUDING THE HIGH VELOCITY HURRICANE ZONE.
3. APPROVED IMPACT PROTECTIVE SYSTEM IS NOT REQUIRED FOR THIS PRODUCT IN WIND BORNE DEBRIS REGIONS. INDIVIDUAL UNITS ATTACHED TO MULLIONS MUST BE IMPACT RATED.
4. ADEQUACY OF THE EXISTING STRUCTURAL CONCRETE/MASONRY AND 2X FRAMING AS A MAIN WIND FORCE RESISTING SYSTEM CAPABLE OF WITHSTANDING AND TRANSFERRING APPLIED PRODUCT LOADS TO THE FOUNDATION IS THE RESPONSIBILITY OF THE ENGINEER OR ARCHITECT OF RECORD FOR THE PROJECT OF INSTALLATION.
5. 1X AND 2X BUCKS (WHEN USED) SHALL BE DESIGNED AND ANCHORED TO PROPERLY TRANSFER ALL LOADS TO THE STRUCTURE. BUCK DESIGN AND INSTALLATION IS THE RESPONSIBILITY OF THE ENGINEER OR ARCHITECT OF RECORD FOR THE PROJECT OF INSTALLATION.
6. THE INSTALLATION DETAILS DESCRIBED HEREIN ARE GENERIC AND MAY NOT REFLECT ACTUAL CONDITIONS FOR A SPECIFIC SITE. IF SITE CONDITIONS CAUSE INSTALLATION TO DEVIATE FROM THE REQUIREMENTS DETAILED HEREIN, A LICENSED ENGINEER OR ARCHITECT SHALL PREPARE SITE SPECIFIC DOCUMENTS FOR USE WITH THIS DOCUMENT IN NON-HVHZ AREAS. IN HVHZ AREAS, ONE TIME PRODUCT APPROVAL TO BE OBTAINED FROM MIAMI-DADE RER.
7. MULLION & CLIP MATERIAL: ALUMINUM 6005-T5 & 6063-T6 (AS NOTED)
8. MULLIONS MAY BE USED WITH ANY APPROVED FENESTRATION PRODUCT, UNDER SEPARATE APPROVAL.
9. SEE SHEETS 5-9 FOR INSTALLATION ANCHOR REQUIREMENTS FOR SPECIFIC ANCHORING REQUIREMENTS, MULLION CONFIGURATIONS, AND DESIGN LOAD CAPACITIES.
10. DISSIMILAR METALS INCLUDING FASTENERS THAT MAY COME INTO CONTACT WITH ALUMINUM UNIT FRAMING SHALL BE PROTECTED IN ACCORDANCE WITH 6TH EDITION (2017) FLORIDA BUILDING CODE.

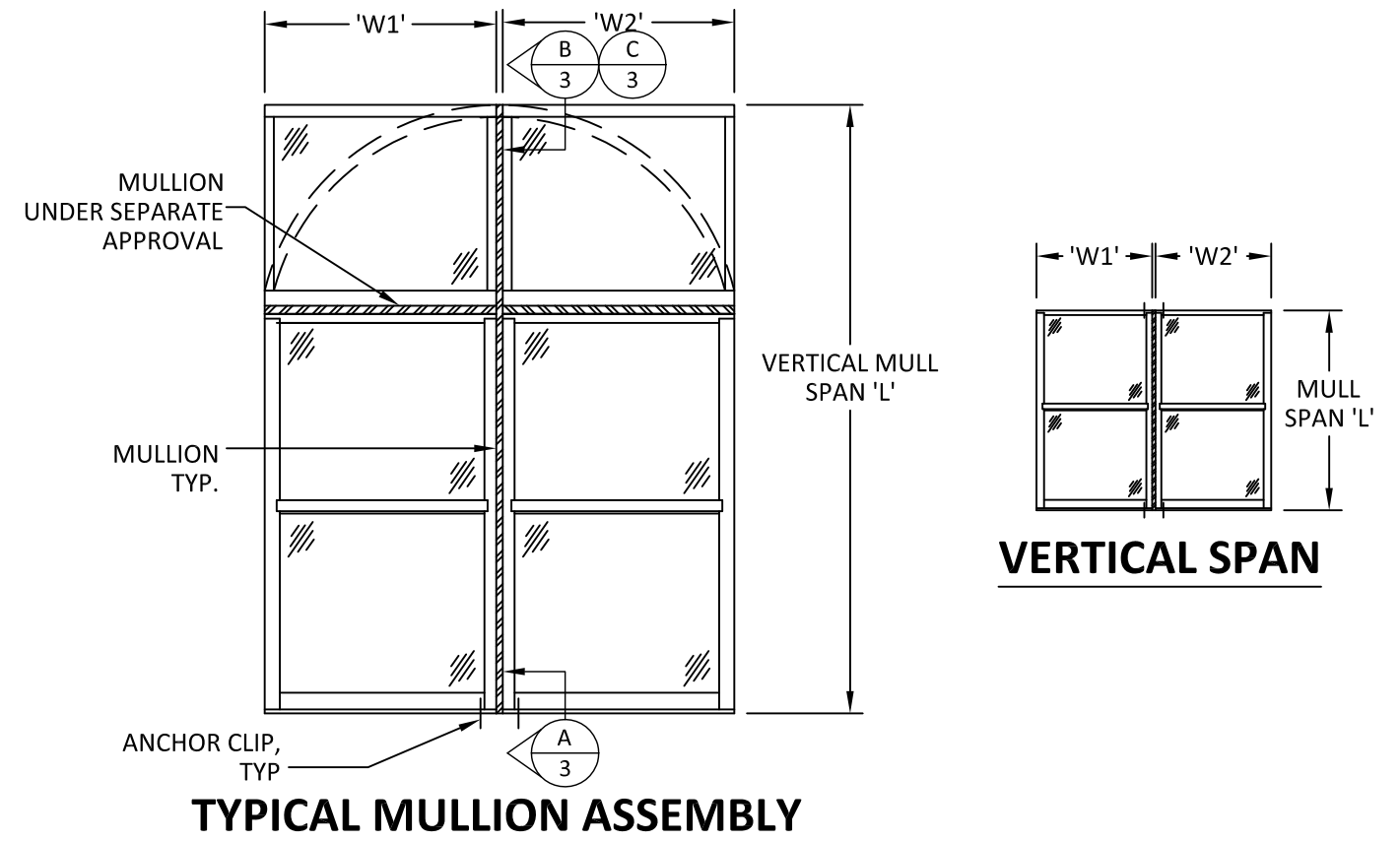
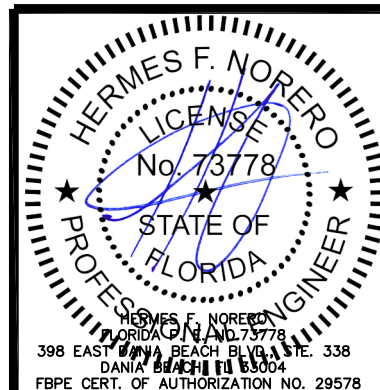

TABLE OF CONTENTS		
SHEET	REVISION	SHEET DESCRIPTION
1	-	GENERAL NOTES, INSTRUCTIONS, AND ELEVATIONS
2	-	MULLION ASSEMBLY AND MULLION AND CLIP DETAILS
3	-	MULLION SECTIONS
4	-	22.50° MULLION DESIGN LOAD TABLES
5	-	45° MULLION DESIGN LOAD TABLES
6	-	90° MULLION DESIGN LOAD TABLES
7	-	MULLION ASSEMBLY AND LOAD EXAMPLES

### INSTRUCTIONS:

1. DETERMINE REQUIRED DESIGN PRESSURE FOR OPENING.
2. CHOOSE A MULLION THAT PROPERLY FITS THE FENESTRATION PRODUCT.
3. DETERMINE WHETHER ASSEMBLY REQUIRES ONE-WAY OR TWO-WAY MULLIONS:
  - ASSEMBLIES CONSISTING OF STACKED OR SIDE-BY-SIDE UNITS REQUIRE USE OF ONE-WAY MULLIONS.
  - ASSEMBLIES CONSISTING OF MULTIPLE UNITS MULLED TOGETHER WITH MULTIPLE MULLIONS REQUIRE USE OF TWO-WAY MULLIONS.
  - SEE SHEET 7 FOR ASSEMBLY EXAMPLES.
  - IF ASSEMBLY TYPE CANNOT BE DETERMINED USE TWO-WAY MULLION CHART.
4. VERIFY THAT MULLION DESIGN PRESSURE MEETS OR EXCEEDS REQUIRED DESIGN PRESSURE OF OPENING USING CHARTS ON SHEETS 4-6.
5. QUALIFIED CLIP TYPES APPEAR ON SHEETS 4-6. MULTIPLE ANCHOR TYPE/SUBSTRATE/CLIP COMBINATIONS WITHIN AN OPENING ARE ALLOWED.
6. MULLIONS SHOWN HEREIN SHALL BE USED IN A VERTICAL MANNER ONLY. HOWEVER, HORIZONTAL MULLIONS UNDER SEPARATE APPROVAL MAY BE USED IN CONJUNCTION WITH MULLIONS SHOWN HEREIN IN A TWO-WAY CONFIGURATION.
7. THE LESSER DESIGN PRESSURE OF MULLION OR FENESTRATION PRODUCT WILL GOVERN OVERALL ASSEMBLY DESIGN PRESSURE RATING.



REVISIONS			
SM	DATE	DESCRIPTION	REV
SM	2/6/18	6TH ED. FBC UPDATES	1
BY	DATE	DESCRIPTION	REV



EASTERN ARCHITECTURAL SYSTEMS  
A DIVISION OF  
EASTERN METAL SUPPLY  
16341 DOMESTIC AVE.  
FT MYERS, FL 33912  
1-877-401-2190

TITLE: HVHZ CLIPPED ALUMINUM BAY/BOW MULLIONS  
VERTICAL AND HORIZONTAL CONFIGURATIONS  
GENERAL AND INSTALLATION NOTES

DATE: 02/05/13 DRAWN BY: TJH PREPARED BY:

DRAWING NO: PA-0004 SCALE: N.T.S.

SHEET: 1 OF 7 REV: -



BUILDING DROPS, INC.  
FBPE CERTIFICATE OF  
AUTHORIZATION NO. 29578

NOTE: USE (2) ANGLE CLIPS PER MULLION END. INSERT CLIPS INSIDE MULLION

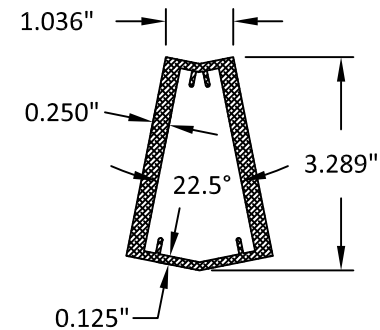
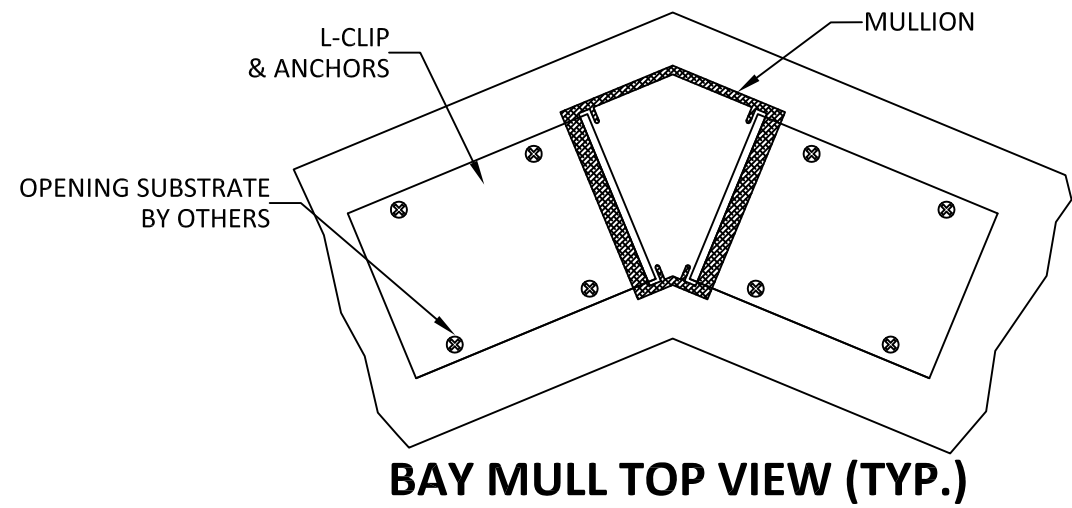

**22.50 DEGREE MULLION**

USE WITH CLIP TYPE(S):  
 • L-CLIPS (PAIRS)  
 USE CLIP DEPTH= 2-3/4"

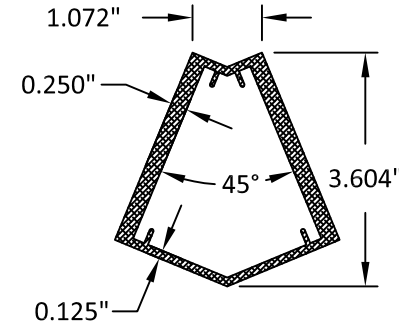

**45 DEGREE MULLION**

USE WITH CLIP TYPE(S):  
 • L-CLIPS (PAIRS)  
 USE CLIP DEPTH= 2-3/4"

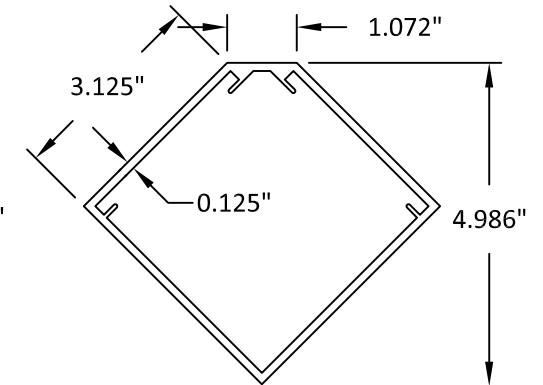

**90 DEGREE MULLION**

USE WITH CLIP TYPE(S):  
 • L-CLIPS (PAIRS)  
 USE CLIP DEPTH= 2-3/4"

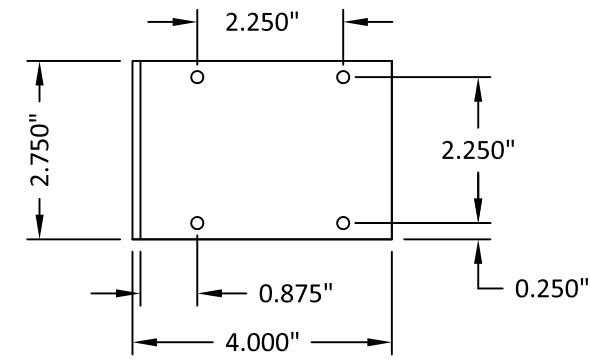

**2" x 4" L-CLIP**

ALUMINUM 6063-T6

L-CLIPS SHALL BE USED IN PAIRS AT MULLION ENDS.

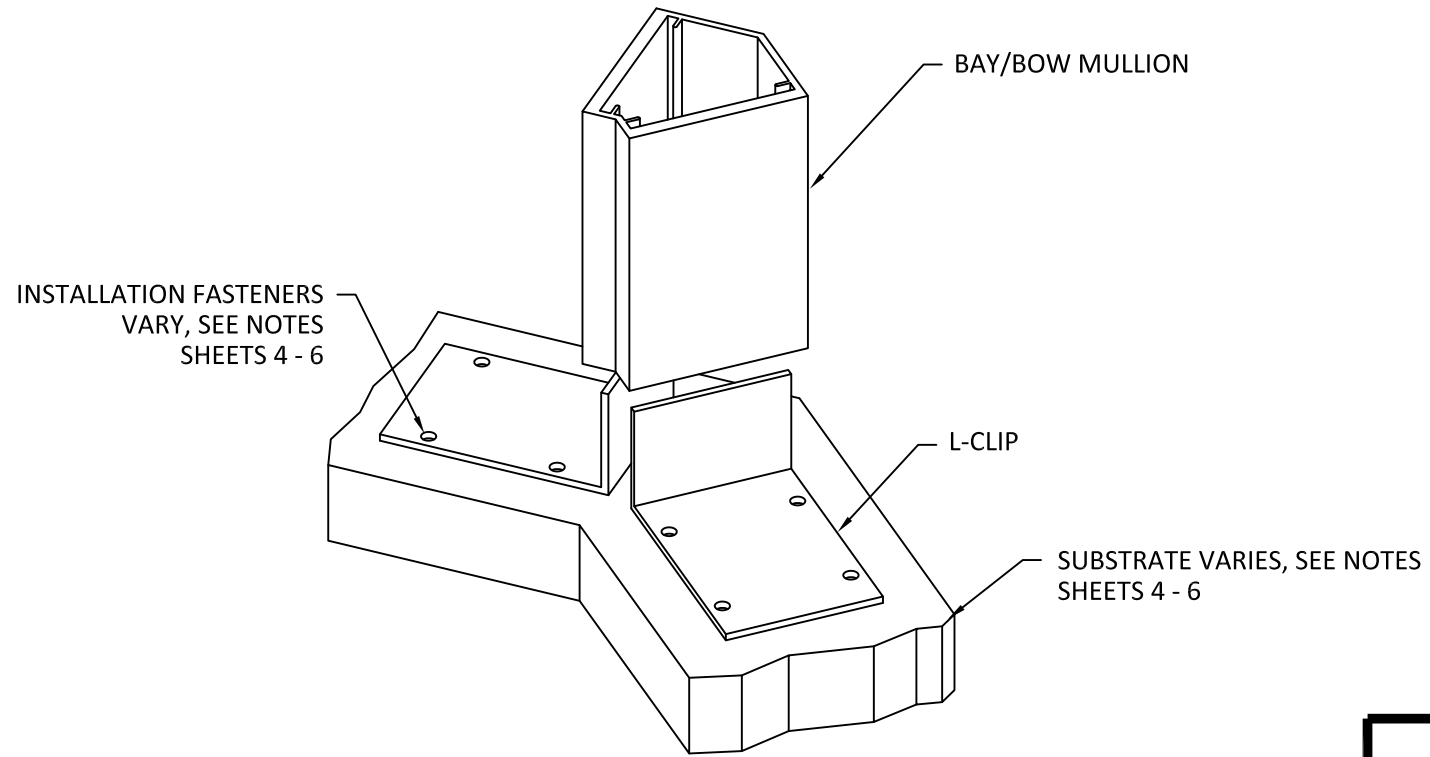

**L-CLIP ATTACHMENT (TYP.)**

NOTE: L-CLIPS MUST BE USED WITH ANY 'BAY/BOW' MULLION TYPE. SEE SPECIFIC MULLION SHEET FOR DETAILS.

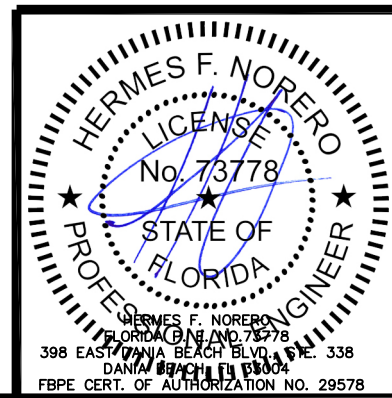

REVISIONS			
BY	DATE	DESCRIPTION	REV



**Eastern**  
ARCHITECTURAL SYSTEMS  
ALUMINUM AND VINYL  
IMPACT WINDOWS AND DOORS

EASTERN ARCHITECTURAL SYSTEMS  
A DIVISION OF  
EASTERN METAL SUPPLY

16341 DOMESTIC AVE.  
FT MYERS, FL 33912  
1-877-401-2190

TITLE: HVHZ CLIPPED ALUMINUM BAY/BOW MULLIONS VERTICAL AND HORIZONTAL CONFIGURATIONS MULLION ASSEMBLY AND MULLION AND CLIP DETAILS

DATE: 02/05/13	DRAWN BY: TJH	PREPARED BY:
DRAWING NO: PA-0004	SCALE: N.T.S.	 BUILDING DROPS, INC. FBPE CERTIFICATE OF AUTHORIZATION NO. 29578
SHEET: 2 OF 7	REV: -	

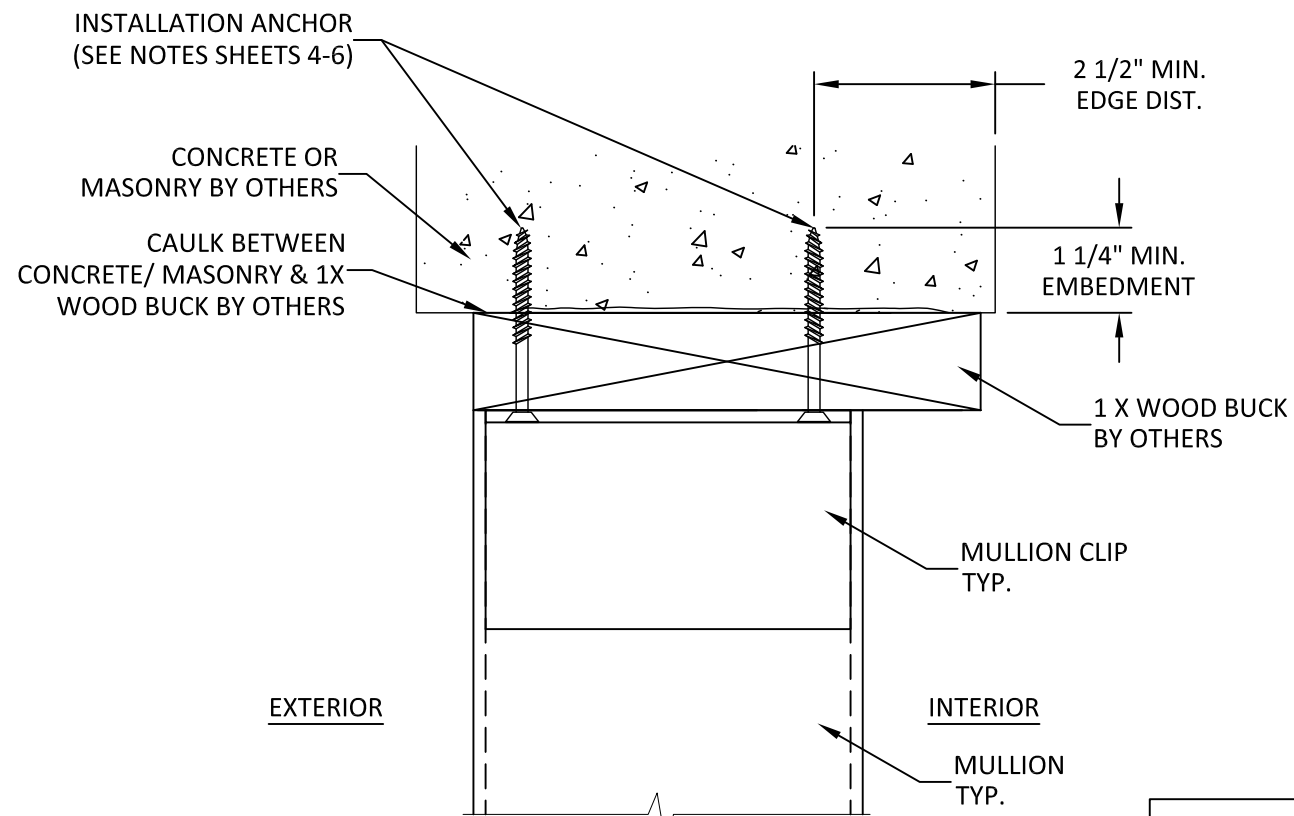

**B**  
**3** **VERTICAL SECTION**  
HEAD - CONCRETE/MASONRY  
SIDE VIEW-VERTICAL

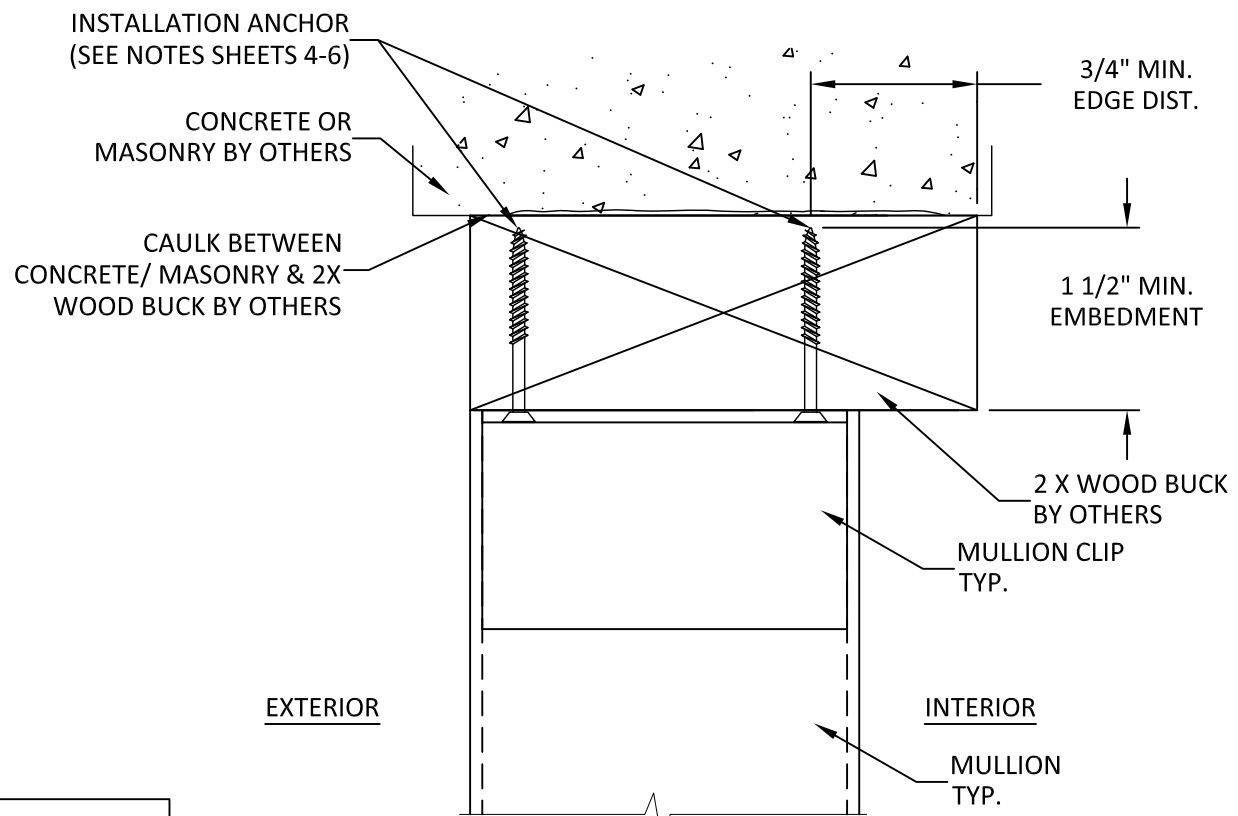

**C**  
**3** **VERTICAL SECTION**  
HEAD - 2X WOOD BUCK  
SIDE VIEW-VERTICAL

NOTE

DETAILS SHOWN ARE TYPICAL FOR ALL MULLION & CLIP ASSEMBLIES. SEE SHEETS 4-6 FOR ALLOWABLE MULLION CONFIGURATIONS, SIZES, AND DESIGN PRESSURES.

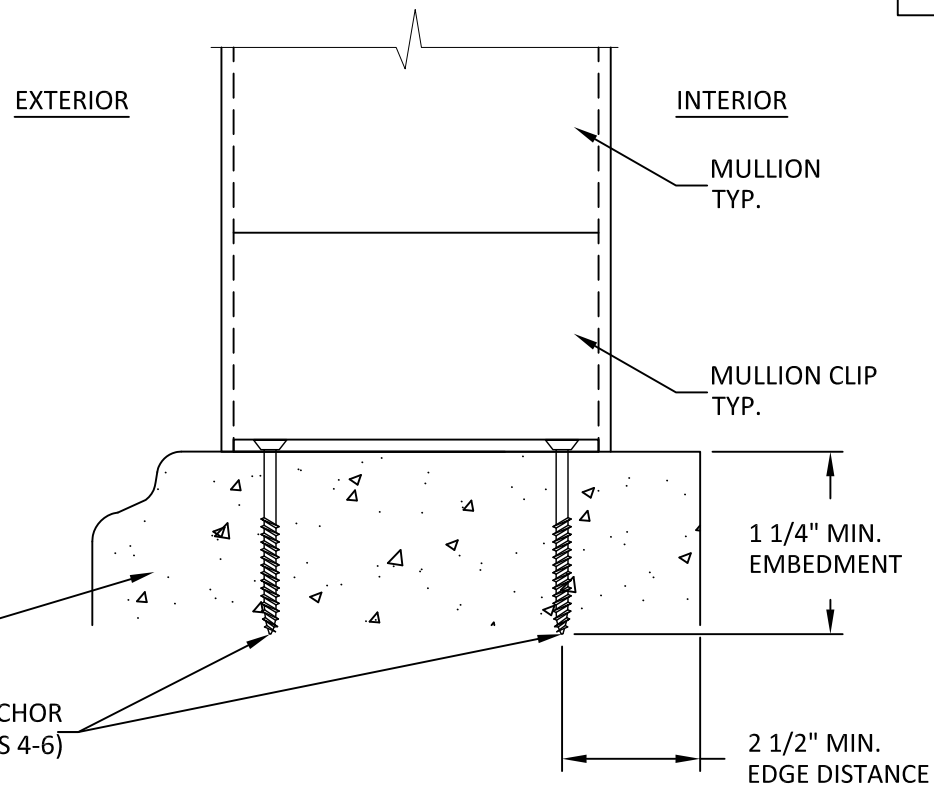

**A**  
**3** **VERTICAL SECTION**  
SILL - CONCRETE/MASONRY  
SIDE VIEW-VERTICAL



REVISIONS			
BY	DATE	DESCRIPTION	REV



**Eastern**  
ARCHITECTURAL SYSTEMS  
ALUMINUM AND VINYL  
IMPACT WINDOWS AND DOORS

EASTERN ARCHITECTURAL SYSTEMS  
A DIVISION OF  
EASTERN METAL SUPPLY

16341 DOMESTIC AVE.  
FT MYERS, FL 33912  
1-877-401-2190

---

TITLE: HVHZ CLIPPED ALUMINUM BAY/BOW MULLIONS  
VERTICAL AND HORIZONTAL CONFIGURATIONS  
MULLION SECTIONS

DATE: 02/05/13	DRAWN BY: TJH	PREPARED BY:
DRAWING NO: PA-0004	SCALE: N.T.S.	 <p>BUILDING DROPS, INC. FBPE CERTIFICATE OF AUTHORIZATION NO. 29578</p>
SHEET: 3 OF 7	REV: -	

DESIGN PRESSURE LIMITS FOR MULLION: 22.5 Deg. - ONE-WAY MULLIONS									
SPAN 'L' (IN.)	TRIBUTARY WIDTH 'W' (IN.)								
	18	24	30	36	42	48	53.125	54	60
24	200.0	200.0	200.0	200.0	200.0	200.0	200.0	200.0	200.0
36	200.0	200.0	200.0	200.0	200.0	200.0	200.0	200.0	200.0
48	200.0	200.0	200.0	200.0	200.0	200.0	200.0	200.0	200.0
60	200.0	200.0	200.0	175.3	159.1	149.0	144.1	143.5	141.6
72	179.3	137.2	112.6	96.9	86.2	78.9	74.6	74.0	70.8
84	112.1	85.4	69.6	59.4	52.3	47.2	44.1	43.6	40.9
96	74.8	56.7	46.1	39.1	34.2	30.7	28.4	28.0	26.0
108	52.3	39.6	32.1	27.1	23.6	21.1	19.4	19.1	17.7

DESIGN PRESSURE LIMITS FOR MULLION: 22.5 Deg. - TWO-WAY MULLIONS									
SPAN 'L' (IN.)	TRIBUTARY WIDTH 'W' (IN.)								
	18	24	30	36	42	48	53.125	54	60
24	200.0	200.0	200.0	200.0	200.0	200.0	200.0	200.0	200.0
36	200.0	200.0	200.0	200.0	200.0	200.0	187.5	184.5	166.0
48	200.0	200.0	200.0	200.0	177.9	155.7	140.6	138.4	124.5
60	200.0	200.0	181.3	151.1	129.5	113.3	102.4	100.7	90.6
72	174.8	131.1	104.9	87.4	74.9	65.6	59.2	58.3	52.5
84	110.1	82.6	66.1	55.1	47.2	41.3	37.3	36.7	33.0
96	73.8	55.3	44.3	36.9	31.6	27.7	25.0	24.6	22.1
108	51.8	38.9	31.1	25.9	22.2	19.4	17.6	17.3	15.5

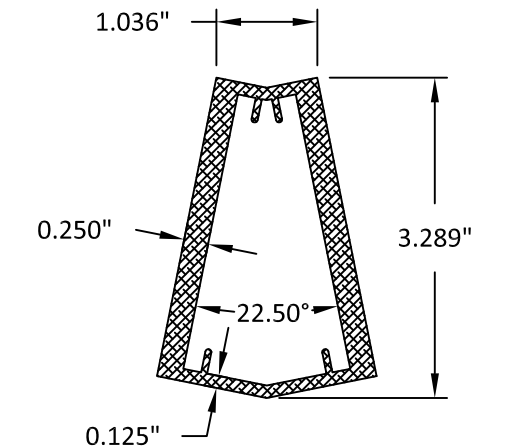

**22.50 DEGREE MULLION**  
ALUMINUM 6005-T5

$$\text{TRIBUTARY WIDTH} = \frac{W1 + W2}{2}$$

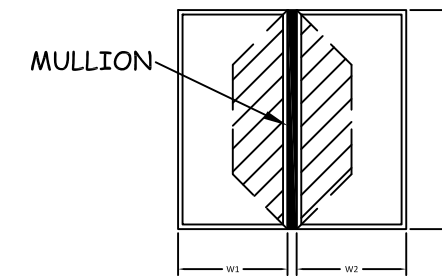

**ONE-WAY MULLION DIAGRAMS**

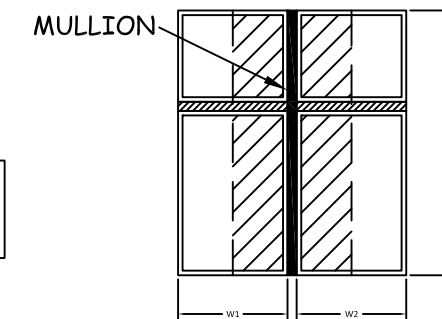

**TWO-WAY MULLION DIAGRAMS**

**QUALIFIED ANCHOR CLIPS**

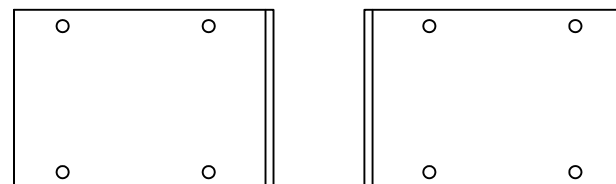

**L-CLIP**

ALUMINUM 6063-T6  
\*\*MUST BE USED IN PAIRS

NOTE: SEE SHEET 2 FOR SPECIFIC CLIP DIMENSIONS.

**TABLE NOTES:**

- SEE SHEET 1 FOR INSTRUCTIONS ON USING TABLES. SEE SHEETS 2-3 FOR TYPICAL INSTALLATION METHODS & CLIP DETAILS.
- LINEAR INTERPOLATION BETWEEN LISTED WIDTHS AND SPANS IS ALLOWED.
- SEE THIS SHEET FOR SPECIFIC MULLION DIMENSIONS.
- SEE SHEET 3 FOR SPECIFIC CLIP DIMENSIONS.
- ANCHOR REQUIREMENTS:
  - WOOD: #14 WOOD SCREWS
  - CMU: 1/4" ITW TAPCONS
  - CONCRETE: 1/4" ITW TAPCONS
  - METAL: 1/4" SELF-DRILLING SCREWS (GRADE 5)
- INSTALLATION SUBSTRATES:
  - WOOD ANCHORS SHALL HAVE A MIN. EMBEDMENT OF 1-1/2" & EDGE DISTANCE OF 1". WOOD SHALL BE MIN. S.G.=0.55.
  - HOLLOW CMU ANCHORS SHALL HAVE A MIN. EMBEDMENT OF 1-1/4" & EDGE DISTANCE OF 2-1/2". HOLLOW CMU SHALL BE MEDIUM WEIGHT CONFORMING TO ASTM C 90.
  - CONCRETE ANCHORS SHALL HAVE A MIN. EMBEDMENT OF 1-3/4" & EDGE DISTANCE OF 2-1/2". CONCRETE SHALL BE MIN. 4000 PSI.
  - METAL ANCHORS SHALL HAVE A MIN. (3) THREADS PENETRATION BEYOND METAL STRUCTURE. STEEL SHALL BE MIN. 18 GA. (0.045" THICK) 33 KSI YIELD. ALUMINUM SHALL BE MIN. 1/8" THICK ALUMINUM 6063-T5.

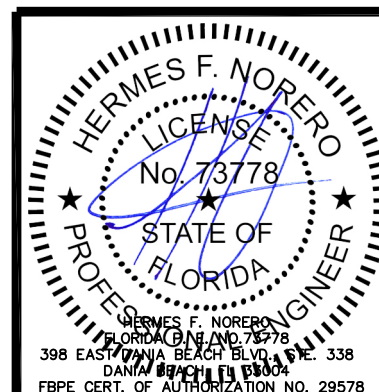

REVISIONS			
BY	DATE	DESCRIPTION	REV



**Eastern**  
ARCHITECTURAL SYSTEMS  
ALUMINUM AND VINYL  
IMPACT WINDOWS AND DOORS

EASTERN ARCHITECTURAL SYSTEMS  
A DIVISION OF  
EASTERN METAL SUPPLY

16341 DOMESTIC AVE.  
FT MYERS, FL 33912  
1-877-401-2190

TITLE: HVHZ CLIPPED ALUMINUM BAY/BOW MULLIONS VERTICAL AND HORIZONTAL CONFIGURATIONS 22.5° MULLION

DATE: 02/05/13	DRAWN BY: TJH	PREPARED BY:
DRAWING NO: PA-0004	SCALE: N.T.S.	 BUILDING DROPS, INC. FBPE CERTIFICATE OF AUTHORIZATION NO. 29578
SHEET: 4 OF 7	REV: -	

DESIGN PRESSURE LIMITS FOR MULLION: 45 Deg. - ONE-WAY MULLIONS									
SPAN 'L' (IN.)	TRIBUTARY WIDTH 'W' (IN.)								
	18	24	30	36	42	48	53.125	54	60
24	200.0	200.0	200.0	200.0	200.0	200.0	200.0	200.0	200.0
36	200.0	200.0	200.0	200.0	200.0	200.0	200.0	200.0	200.0
48	200.0	200.0	200.0	200.0	200.0	200.0	200.0	200.0	200.0
60	200.0	200.0	200.0	200.0	192.2	180.0	174.1	173.4	171.1
72	200.0	165.8	136.1	117.0	104.2	95.4	90.1	89.4	85.5
84	135.4	103.1	84.1	71.7	63.2	57.1	53.2	52.7	49.5
96	90.3	68.5	55.6	47.2	41.3	37.0	34.3	33.8	31.4
108	63.2	47.9	38.7	32.7	28.5	25.5	23.4	23.1	21.3

DESIGN PRESSURE LIMITS FOR MULLION: 45 Deg. - TWO-WAY MULLIONS									
SPAN 'L' (IN.)	TRIBUTARY WIDTH 'W' (IN.)								
	18	24	30	36	42	48	53.125	54	60
24	200.0	200.0	200.0	200.0	200.0	200.0	200.0	200.0	200.0
36	200.0	200.0	200.0	200.0	200.0	200.0	187.5	184.5	166.0
48	200.0	200.0	200.0	200.0	177.9	155.7	140.6	138.4	124.5
60	200.0	200.0	199.2	166.0	142.3	124.5	112.5	110.7	99.6
72	200.0	158.4	126.7	105.6	90.5	79.2	71.6	70.4	63.4
84	133.0	99.8	79.8	66.5	57.0	49.9	45.1	44.3	39.9
96	89.1	66.8	53.5	44.6	38.2	33.4	30.2	29.7	26.7
108	62.6	46.9	37.6	31.3	26.8	23.5	21.2	20.9	18.8

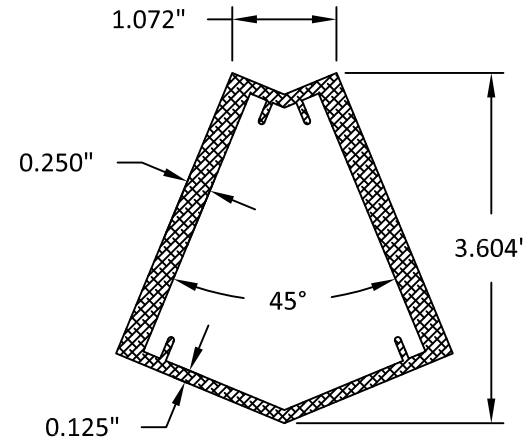

**45 DEGREE MULLION**

ALUMINUM 6005-T5

$$\text{TRIBUTARY WIDTH} = \frac{W1 + W2}{2}$$

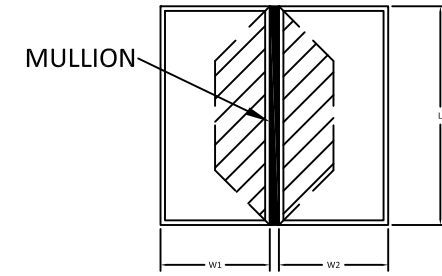

**ONE-WAY MULLION DIAGRAMS**

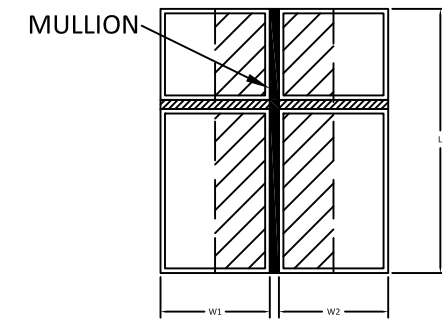

**TWO-WAY MULLION DIAGRAMS**

**TABLE NOTES:**

- SEE SHEET 1 FOR INSTRUCTIONS ON USING TABLES. SEE SHEETS 2-3 FOR TYPICAL INSTALLATION METHODS & CLIP DETAILS.
- LINEAR INTERPOLATION BETWEEN LISTED WIDTHS AND SPANS IS ALLOWED.
- SEE THIS SHEET FOR SPECIFIC MULLION DIMENSIONS.
- SEE SHEET 3 FOR SPECIFIC CLIP DIMENSIONS.
- ANCHOR REQUIREMENTS:
  - WOOD: #14 WOOD SCREWS
  - CMU: 1/4" ITW TAPCONS
  - CONCRETE: 1/4" ITW TAPCONS
  - METAL: 1/4" SELF-DRILLING SCREWS (GRADE 5)
- INSTALLATION SUBSTRATES:
  - WOOD ANCHORS SHALL HAVE A MIN. EMBEDMENT OF 1-1/2" & EDGE DISTANCE OF 1". WOOD SHALL BE MIN. S.G.=0.55.
  - HOLLOW CMU ANCHORS SHALL HAVE A MIN. EMBEDMENT OF 1-1/4" & EDGE DISTANCE OF 2-1/2". HOLLOW CMU SHALL BE MEDIUM WEIGHT CONFORMING TO ASTM C 90.
  - CONCRETE ANCHORS SHALL HAVE A MIN. EMBEDMENT OF 1-3/4" & EDGE DISTANCE OF 2-1/2". CONCRETE SHALL BE MIN. 4000 PSI.
  - METAL ANCHORS SHALL HAVE A MIN. (3) THREADS PENETRATION BEYOND METAL STRUCTURE. STEEL SHALL BE MIN. 18 GA. (0.045" THICK) 33 KSI YIELD. ALUMINUM SHALL BE MIN. 1/8" THICK ALUMINUM 6063-T5.

**QUALIFIED ANCHOR CLIPS**

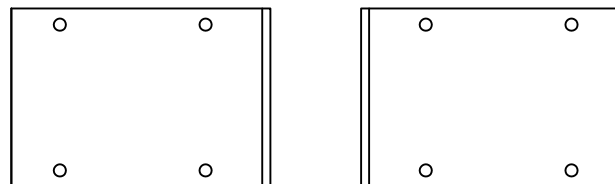

**L-CLIP**

ALUMINUM 6063-T6  
\*\*MUST BE USED IN PAIRS

NOTE: SEE SHEET 2 FOR SPECIFIC CLIP DIMENSIONS.

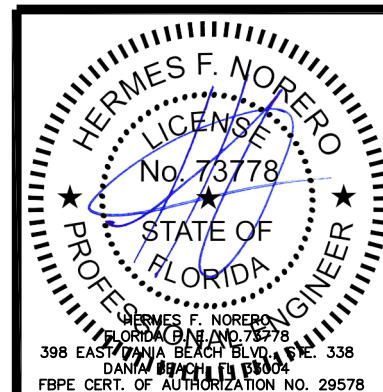

REVISIONS			
BY	DATE	DESCRIPTION	REV



EASTERN ARCHITECTURAL SYSTEMS  
A DIVISION OF  
EASTERN METAL SUPPLY  
16341 DOMESTIC AVE.  
FT MYERS, FL 33912  
1-877-401-2190

TITLE: HVHZ CLIPPED ALUMINUM BAY/BOW MULLIONS VERTICAL AND HORIZONTAL CONFIGURATIONS 45° MULLION			
DATE: 02/05/13	DRAWN BY: TJH	PREPARED BY:	
DRAWING NO: PA-0004	SCALE: N.T.S.	BUILDING DROPS, INC. FBPE CERTIFICATE OF AUTHORIZATION NO. 29578	
SHEET: 5 OF 7	REV:	-	

DESIGN PRESSURE LIMITS FOR MULLION: 90 Deg. - ONE-WAY MULLIONS									
SPAN 'L' (IN.)	TRIBUTARY WIDTH 'W' (IN.)								
	18	24	30	36	42	48	53.125	54	60
24	200.0	200.0	200.0	200.0	200.0	200.0	200.0	200.0	200.0
36	200.0	200.0	200.0	200.0	200.0	200.0	200.0	200.0	200.0
48	200.0	200.0	200.0	200.0	200.0	200.0	200.0	200.0	200.0
60	200.0	200.0	200.0	200.0	200.0	200.0	200.0	200.0	199.2
72	200.0	200.0	200.0	184.5	167.4	155.7	148.6	147.6	142.3
84	200.0	183.3	149.5	127.5	112.3	101.5	94.6	93.6	87.9
96	160.5	121.8	98.9	83.9	73.4	65.8	60.9	60.2	55.9
108	112.4	85.1	68.9	58.2	50.7	45.2	41.6	41.1	37.9

DESIGN PRESSURE LIMITS FOR MULLION: 90 Deg. - TWO-WAY MULLIONS									
SPAN 'L' (IN.)	TRIBUTARY WIDTH 'W' (IN.)								
	18	24	30	36	42	48	53.125	54	60
24	200.0	200.0	200.0	200.0	200.0	200.0	200.0	200.0	200.0
36	200.0	200.0	200.0	200.0	200.0	200.0	187.5	184.5	166.0
48	200.0	200.0	200.0	200.0	177.9	155.7	140.6	138.4	124.5
60	200.0	200.0	199.2	166.0	142.3	124.5	112.5	110.7	99.6
72	200.0	200.0	166.0	138.4	118.6	103.8	93.8	92.2	83.0
84	200.0	177.3	141.9	118.2	101.3	88.7	80.1	78.8	70.9
96	158.4	118.8	95.0	79.2	67.9	59.4	53.7	52.8	47.5
108	111.2	83.4	66.7	55.6	47.7	41.7	37.7	37.1	33.4

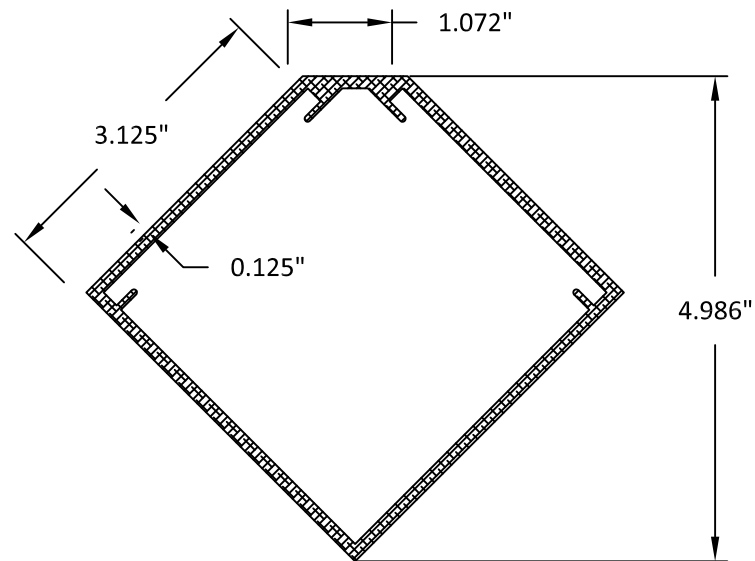

### 90 DEGREE MULLION

ALUMINUM 6005-T5

$$\text{TRIBUTARY WIDTH} = \frac{W1 + W2}{2}$$

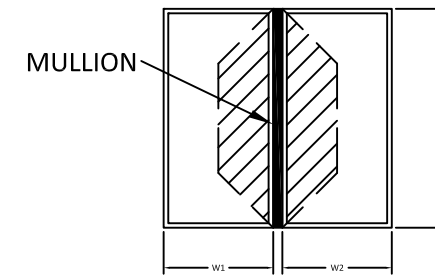

### ONE-WAY MULLION DIAGRAMS

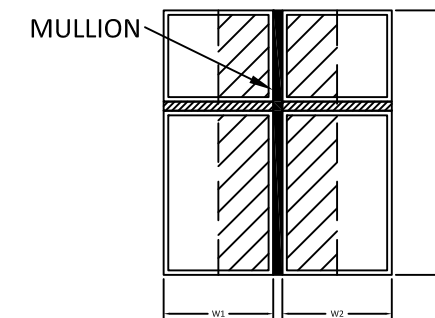

### TWO-WAY MULLION DIAGRAMS

### QUALIFIED ANCHOR CLIPS

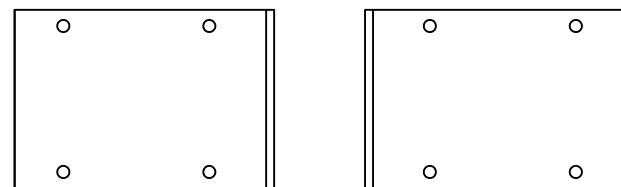

### L-CLIP

ALUMINUM 6063-T6  
\*\*MUST BE USED IN PAIRS

NOTE: SEE SHEET 2 FOR SPECIFIC CLIP DIMENSIONS.

#### TABLE NOTES:

- SEE SHEET 1 FOR INSTRUCTIONS ON USING TABLES. SEE SHEETS 2-3 FOR TYPICAL INSTALLATION METHODS & CLIP DETAILS.
- LINEAR INTERPOLATION BETWEEN LISTED WIDTHS AND SPANS IS ALLOWED.
- SEE THIS SHEET FOR SPECIFIC MULLION DIMENSIONS.
- SEE SHEET 3 FOR SPECIFIC CLIP DIMENSIONS.
- ANCHOR REQUIREMENTS:
  - WOOD: #14 WOOD SCREWS
  - CMU: 1/4" ITW TAPCONS
  - CONCRETE: 1/4" ITW TAPCONS
  - METAL: 1/4" SELF-DRILLING SCREWS (GRADE 5)
- INSTALLATION SUBSTRATES:
  - WOOD ANCHORS SHALL HAVE A MIN. EMBEDMENT OF 1-1/2" & EDGE DISTANCE OF 1". WOOD SHALL BE MIN. S.G.=0.55.
  - HOLLOW CMU ANCHORS SHALL HAVE A MIN. EMBEDMENT OF 1-1/4" & EDGE DISTANCE OF 2-1/2". HOLLOW CMU SHALL BE MEDIUM WEIGHT CONFORMING TO ASTM C 90.
  - CONCRETE ANCHORS SHALL HAVE A MIN. EMBEDMENT OF 1-3/4" & EDGE DISTANCE OF 2-1/2". CONCRETE SHALL BE MIN. 4000 PSI.
  - METAL ANCHORS SHALL HAVE A MIN. (3) THREADS PENETRATION BEYOND METAL STRUCTURE. STEEL SHALL BE MIN. 18 GA. (0.045" THICK) 33 KSI YIELD. ALUMINUM SHALL BE MIN. 1/8" THICK ALUMINUM 6063-T5.

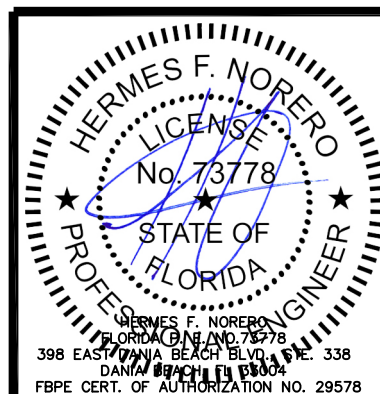

REVISIONS			
BY	DATE	DESCRIPTION	REV

**Eastern**  
ARCHITECTURAL SYSTEMS  
ALUMINUM AND VINYL  
IMPACT WINDOWS AND DOORS

EASTERN ARCHITECTURAL SYSTEMS  
A DIVISION OF  
EASTERN METAL SUPPLY

16341 DOMESTIC AVE.  
FT MYERS, FL 33912  
1-877-401-2190

---

TITLE: HVHZ CLIPPED ALUMINUM BAY/BOW MULLIONS  
VERTICAL AND HORIZONTAL CONFIGURATIONS  
90° MULLION

DATE: 02/05/13	DRAWN BY: TJH	PREPARED BY:
DRAWING NO: PA-0004	SCALE: N.T.S.	<p>BUILDING DROPS, INC. FBPE CERTIFICATE OF AUTHORIZATION NO. 29578</p>
SHEET: 6 OF 7	REV: -	

**EXAMPLES OF TWO-WAY MULLION ASSEMBLIES**

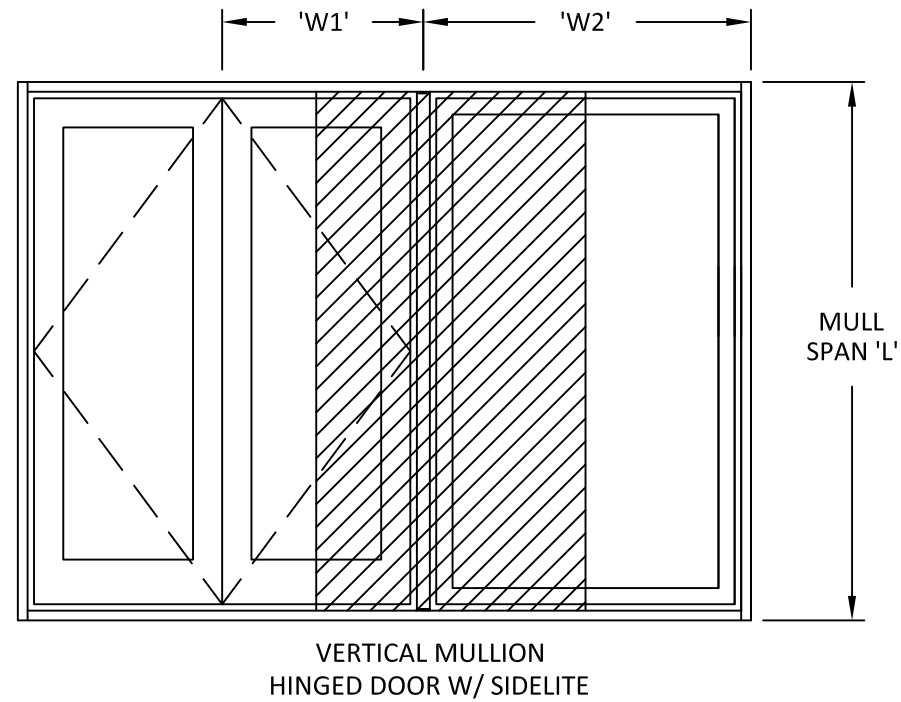
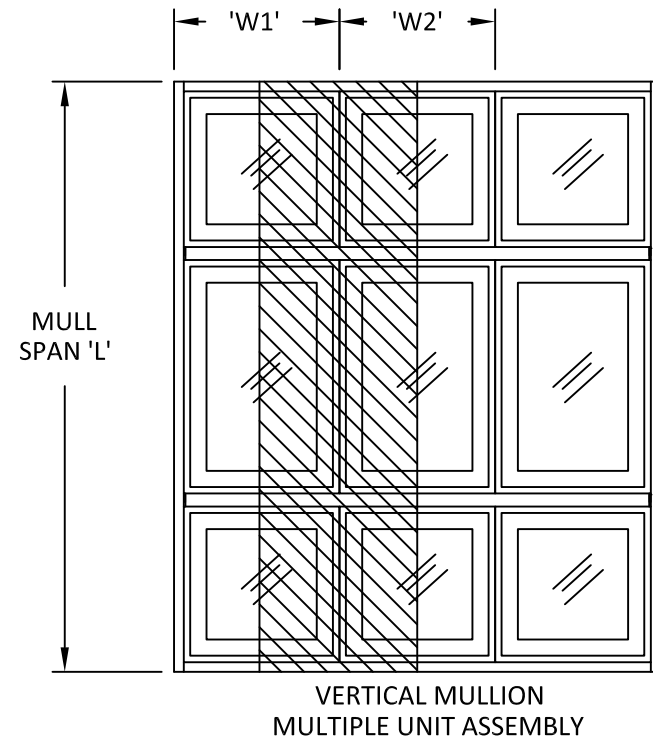

**EXAMPLES OF ONE-WAY MULLION ASSEMBLIES**

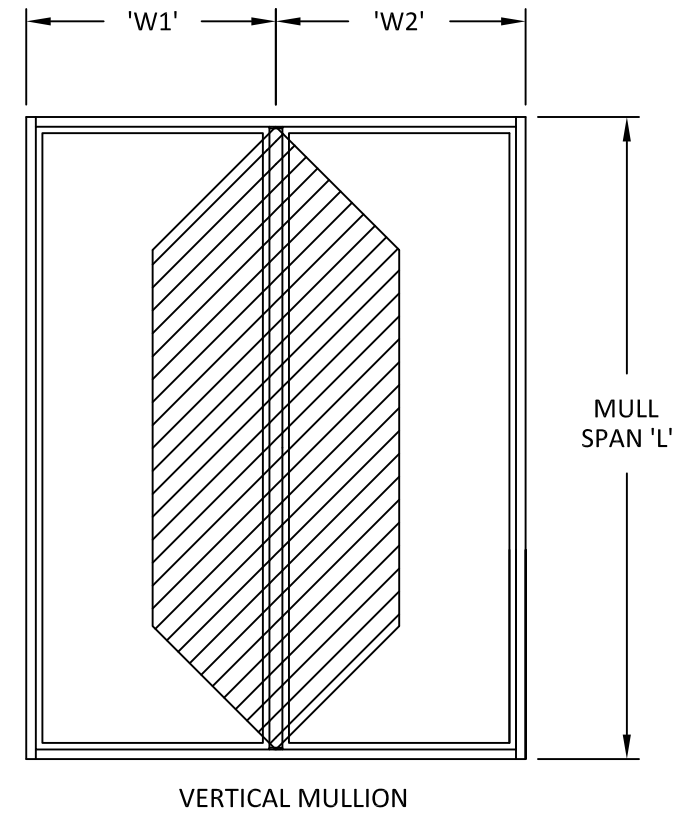

- NOTES:**
1. DRAWINGS ARE DIAGRAMMATIC IN NATURE AND CONFIGURATIONS NOT SPECIFICALLY SHOWN MAY BE EXTRAPOLATED FROM THOSE SHOWN.
  2. IF THE LOADING TYPE CANNOT BE DETERMINED, USE TWO-WAY ASSEMBLY CONFIGURATION VALUES.
  3. FENESTRATION PRODUCTS SHALL BE ANCHORED AS APPROVED.



REVISIONS			
BY	DATE	DESCRIPTION	REV



**Eastern**  
ARCHITECTURAL SYSTEMS  
ALUMINUM AND VINYL  
IMPACT WINDOWS AND DOORS

EASTERN ARCHITECTURAL SYSTEMS  
A DIVISION OF  
EASTERN METAL SUPPLY

16341 DOMESTIC AVE.  
FT MYERS, FL 33912  
1-877-401-2190

TITLE: HVHZ CLIPPED ALUMINUM BAY/BOW MULLIONS  
VERTICAL AND HORIZONTAL CONFIGURATIONS  
MULLION ASSEMBLY AND LOAD EXAMPLES

DATE: 02/05/13	DRAWN BY: TJH	PREPARED BY:
DRAWING NO: PA-0004	SCALE: N.T.S.	 BUILDING DROPS, INC. FBPE CERTIFICATE OF AUTHORIZATION NO. 29578
SHEET: 7 OF 7	REV: -	